



JARAMOGI OGINGA ODINGA UNIVERSITY OF SCIENCE AND TECHNOLOGY

SCHOOL OF ENGINEERING AND TECHNOLOGY

**UNIVERSITY EXAMINATION RESITS/ SPECIAL FOR THE DEGREE IN SCIENCE IN
CONSTRUCTION MANAGEMENT**

3RD YEAR 1ST SEMESTER 2022/2023 ACADEMIC YEAR

CENTRE: MAIN CAMPUS

COURSE CODE: TCB 1301

COURSE TITLE: STRUCTURES II

EXAM VENUE: STREAM: BSc. CONSTRUCTION MGT

DURATION: 2 HOURS

Instructions

- 1. Answer question 1 (Compulsory) and ANY other TWO (2) questions**
- 2. Candidates are advised not to write on question paper**
- 3. Candidates must hand in their answer booklets to the invigilator while in the examination room.**

QUESTION ONE (30 Marks)

- a. List FIVE (5) benefits of using Eurocode 2? (5 Marks).
- b. Eurocode: Basis of Structural Design, establishes THREE (3) principles and requirements for structures. List them? (3 Marks).
- c. For each variable action there are four representative values. List and describe the FOUR (4)? (4 Marks).
- d. Provide definitions for the respective Eurocode symbols)? (4 Marks).

Symbol	Definition
G_k	
Q_k	
γ_G	
γ_Q	
ψ_0	
ψ_1	
ψ_2	
ϵ	

- e. In the Eurocodes the term ‘combination of actions’ is specifically used for the definition of the magnitude of actions to be used when a limit state is under the influence of different actions. Describe FOUR (4) process used to determine the value of actions used for analysis)? (4 Marks).
- f. The nominal cover can be assessed as follows:

$$c_{nom} = c_{min} + \Delta c_{dev}$$
 Explain THREE requirements which need to be satisfied to achieve c_{min} ? (3 Marks).
- g. Detail the procedure for carrying out the design of slabs, assuming that the slab thickness has previously been determined during conceptual design? (7 Marks)

QUESTION TWO (20 Marks)

A rectangular reinforced concrete slab is simply supported on two masonry walls 250mm thick and 3.5m apart. The slab has to carry a distributed permanent action of 0.8kN/m² (excluding slab self-weight) and a variable action of 2.4kN/m². The materials to be used are grade C25 concrete and grade 500 reinforcement. The slab is outside buildings which subjected to 1hr fire resistance and design for 50years design life. Assume diameter of bar=12mm. Min. cover with regard to durability, $C_{min,dur} = 20$ mm.

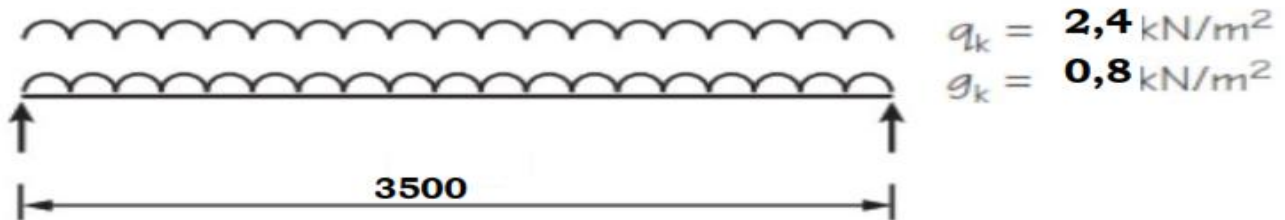

- Estimate thickness of concrete slab considering deflection control? (3 Marks).
- Check for Durability, Fire & Bond Requirements, then determine the nominal cover, C_{nom} ? (3 Marks)
- Determine the Design action, n_d ? (3 Marks).
- Determine shear force and bending moment? (4 Marks).
- Determine the main and distribution reinforcement? (3 Marks).
- Check for shear? (2 Marks).
- Check for deflection? (2 Marks)

QUESTION THREE (20 Marks)

A 480 mm deep \times 290 mm wide rectangular beam is required to support loads of $g_k = 25$ kN/m and $q_k = 9$ kN/m over 2 no. 4.5 m span. $f_{ck} = 30$ MPa, $f_{yk} = 500$ MPa, $f_{yd} = 435$ MPa. Assume 300 mm wide supports, a 50-year design life and a requirement for a 2-hour resistance to fire in an external but sheltered environment. Assume diameter of bar = 20mm and 10mm links.

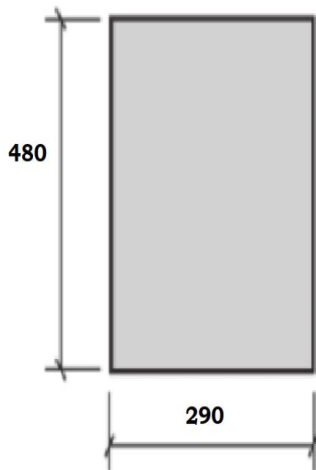
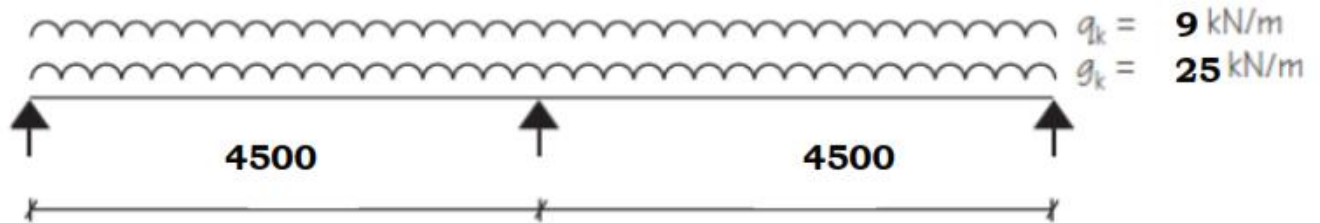

- Check for Durability, Fire & Bond Requirements, then determine the nominal cover, C_{nom} ? (3 Marks).
- Determine the Design action, n_d ? (3 Marks).
- Determine the Design Moments and Shear force? (3 Marks).
- Design for flexure in span and supports? (3 Marks).
- Check for deflection? (3 Marks).
- Design for Shear at the supports? (3 Marks).
- Present a schematic design summary? (2 Marks).

QUESTION FOUR (20 Marks)

A 370 mm square column on the edge of a flat slab structure supports an axial load of 1400 kN and first order moments of 30 kNm top and -30 kNm bottom in one direction only. The concrete is grade C30/37, $f_{ek} = 30$ MPa and cover, $c_{nom} = 25$ mm. The 210 mm thick flat slabs are at 3400 mm vertical centres.

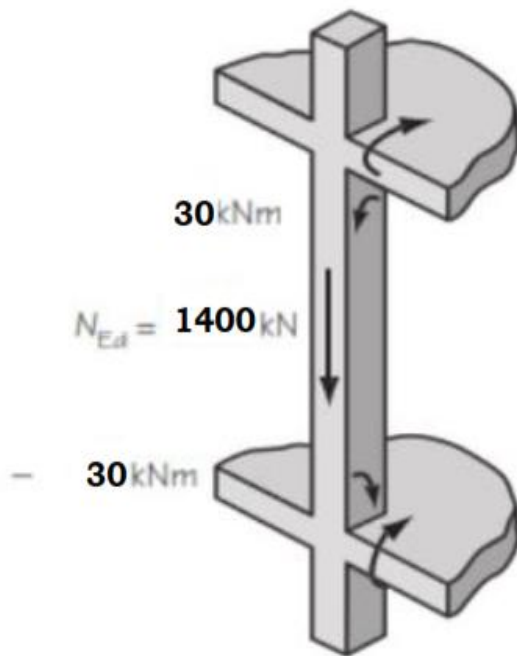

Forces in edge column

- a. Check for slenderness? (4 Marks).
- b. Design maximum moments? (4 Marks).
- c. Design using charts? (4 Marks).
- d. Design for links? (4 Marks).
- e. Present a schematic design summary? (4 Marks).

END