



JARAMOGI OGINGA ODINGA UNIVERSITY OF SCIENCE AND TECHNOLOGY

SCHOOL OF ENGINEERING AND TECHNOLOGY

**UNIVERSITY EXAMINATIONS FOR THE DEGREE IN RENEWABLE ENERGY,
TECHNOLOGY AND MANAGENT**

4THYEAR 1STSEMESTER 2018/2019 ACADEMIC YEAR

CENTRE: MAIN CAMPUS

COURSE CODE: TET 3411

COURSE TITLE: ELECTRIC POWER SYSTEMS

EXAM VENUE:

STREAM: BSc REN ENERGY TECH. &MGT.

DATE: ../12/2018

EXAM SESSION:

DURATION: 2 HOURS

Instructions

- 1. Answer question 1 (Compulsory) and ANY other two questions**
- 2. Candidates are advised not to write on question paper**
- 3. Candidates must hand in their answer booklets to the invigilator while in the examination room**

QUESTION ONE (COMPULSARY)

- a) i). With the help of a diagram, define the term '**Electric Power System**' (2 Marks)
- ii). Power system engineers assist energy authorities to proactively planned for operation, growth and improvement of energy sector. Give five (5) elements that engineers require for power system analysis, to aid in power system planning. (5 marks)
- iii). Engineers modeled power system elements for analysis of load studies, fault calculations and system stability. Briefly explain how the analysis of the elements listed above help engineers to solve power system problems (5 Marks)
- b) There are several types of Power plants in Kenya.
- (i). List 4 of them (2 marks)
- (ii). Briefly explain how each works (4 Marks)
- c) Give three reasons why conventional methods like Kirchhoff's Current and Voltage laws cannot be used in power systems load flow analysis (3 Marks)
- d) Define the Term '**Zones of Protection**' in a power system? (2 Marks)
- e) What is synchronization? (2 Marks)
- f) If a solar farm investor wishes to sell Power (say 2 MVA) to the national grid, list 4 conditions that the generated solar power must meet for it to synchronize with grid. - (2 Marks)
- g) Name 6 types of Faults that may occur whenever there is a short circuit. (3 Marks)

QUESTION TWO

- a. Use Fig Q 2.1 overleaf to answer the questions that follow. This is a one-line diagram model of a generating station, transformers and transmission line.

Fig Q 2.1

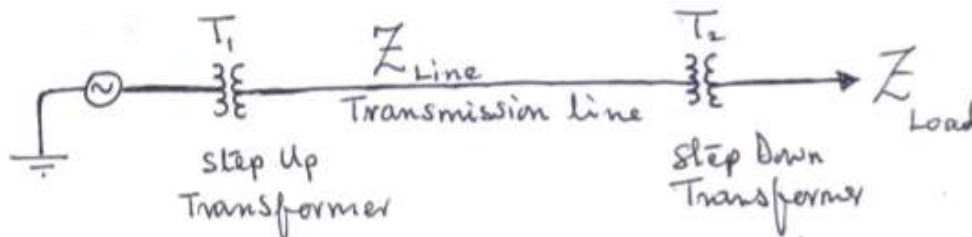

$Z_{\text{Line}} = 10 + j30 \Omega$ and the Transformer ratio is 2 KV/11 KV,

$R_{\text{Line}} =$ resistance on the low-voltage side = 0.04Ω and on High voltage side = 1.3Ω .

$X_{\text{Line}} =$ reactance on the low-voltage and high-voltage side = 0.125Ω and 4.5Ω

- Draw the equivalent circuit diagram and indicate the parameter values on it. **(5 Marks)**
- Calculate line Currents **(3 Marks)**
- The line losses **(2.5 Marks)**
- The output power **(2.5 Marks)**
- The efficiency of the line **(3 Marks)**
- The sending end voltage **(4 Marks)**

QUESTION THREE

- What is Load flow solutions? **(2 Marks)**
- Give two advantages the Newton Raphson method has over the Gauss Seidel method in solving non-linear problems in Power systems load flow analysis. **(3 Marks)**
- Classify various types of busses in a power system for load flow studies. **(4 Marks)**
- Justify each of the above classification. **(4 Marks)**
- Solve this matrix using Gauss Elimination and back substitution **(7 Marks)**

$$\begin{bmatrix} 10 & 5 \\ 2 & 9 \end{bmatrix} \begin{bmatrix} x_1 \\ x_2 \end{bmatrix} = \begin{bmatrix} 6 \\ 3 \end{bmatrix}$$

QUESTION FOUR

- a. State advantages of a three-phase system over a single phase of the same capacity **(3Marks)**
- b. i). With the help of clearly labeled diagrams, differentiate between WYE and MESH transformer windings. Indicate the line and Phase voltages and currents. **(3 Marks)**
 ii). Give two reasons why the transformers used for Extra High Tension transmission are often Mesh and not WYE transformers. **(2 Marks)**
- c. i). Explain the 'per unit system' of analyzing power system problems. **(1 Marks)**
- d. ii). What are the advantages of using Per unit over the absolute method of analysis? **(2 Marks)**
- e. A single phase circuit (Fig Q 4.1) with three zones connected by Transformers T_1 and T_2 , and whose ratings are as shown, has base values of 30kVA and 240 v in Zone 1.

ii). Fig Q 4.1

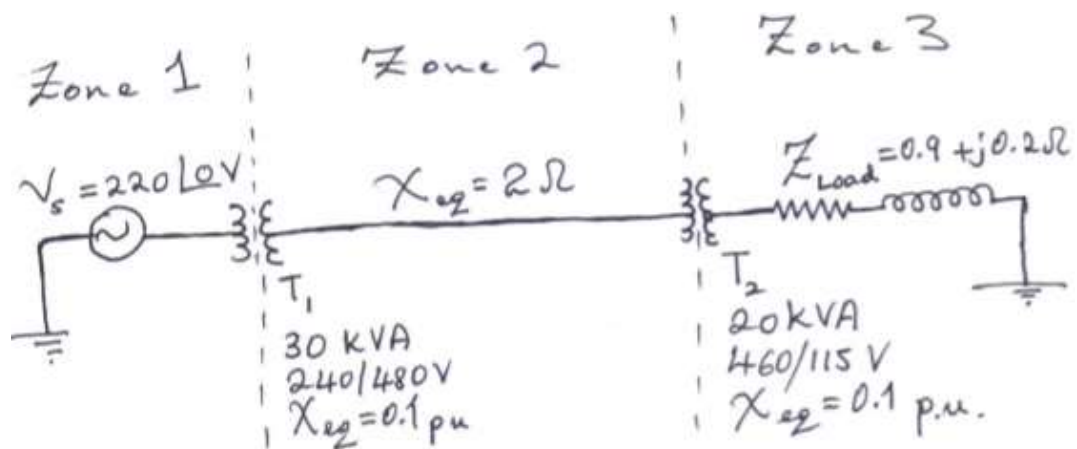

- i). draw the per-unit circuit **(2 Marks)**
- ii). determine the per-unit impedances **(2 Marks)**
- iii). determine the per-unit source voltage. **(2 Marks)**
- iv). Then calculate the load current both in per-unit and in amperes. **(3 Marks)**

Transformer winding resistances and shunt admittance branches are neglected

QUESTION FIVE

- Name three causes of disturbances in a power system operating in a stable condition **(3 Marks)**
- State three methods that can be used to improve steady state stability **(3 Marks)**
- Define switchgear **(1 Mark)**
 - Mention 3 switchgear devices **(3 marks)**
 - What is a protective relay? **(2 Mark)**
- For the zones of protections in a power system shown in the fig Q 5.1, identify and locate where the fault, if the Breakers tripped are: -

Fig Q 5.1

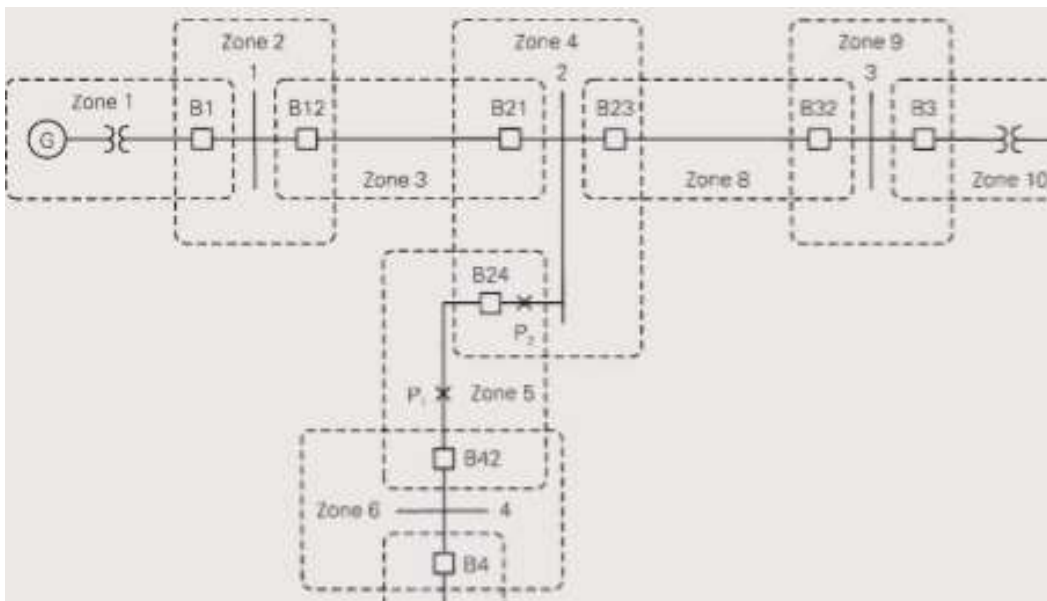

- B12 and B21 **(1 marks)**
- B23 and B32- **(1 marks)**
- B21, B23 and B24- **(2marks)**
- B21, B23, B24 and B42 **(3 marks)**
- B32 and B3 **(1 Marks)**