

# Empirical Analysis of Clustered Network Traffic over Digital Communication Channels

Vincent O. Nyangaresi, S. Ogara, S. Abeka

School Of Informatics and Innovative Systems, Jaramogi Oginga Odinga University of Science & Technology

**Abstract** – The concept of clustering traffic is a noble idea from a number of perspectives. In digital communication channels, signals from different sources are multiplexed at the source and carried on a single communication channel. At the receiver side, a demultiplexer is employed to split the multiplexed signal into its various constituents. In this way, the available channel bandwidth is utilized efficiently, as compared to circuit switched channels. At the packet level, data segments can also be combined and transmitted as a block. This is the basis for asynchronous transfer mode (ATM), integrated service digital network (ISDN), plesiochronous digital hierarchy (PDH), frame relay and synchronous digital hierarchy (SDH). This goal of this paper was to provide an empirical analysis of these clustered techniques in terms of their architecture, carried traffic, data transfer rates, operational strengths and challenges. The objectives were to understand how the architecture of these clustering techniques utilize the available network bandwidth and establish how their structure affects their data communication efficiency. This is significant as it provides a basis upon which new novel clustering mechanism can be developed to address the challenges inherent in one or more of these current clustering techniques. The results indicated that owing to their inflexibility, they cannot adjust to the changing network bandwidth. Moreover, it was noted that some of them contained huge signaling overheads that could effectively lead to wastage of channel resources.

**Index Terms** – Clustering, traffic, ATM, SDH, ISDN, PDH.

## 1. INTRODUCTION

The idea of traffic clustering dates back to the digital telephony era. In voice telephony, a human voice can contain frequency components of up to 20 KHZ. However, for intelligible conversation, a maximum of 3.5 KHZ is found to be adequate [1]. Therefore, in voice telephony, the electrical signal from the microphone is passed through a low pass filter (LPF) to limit the maximum frequency content to 3.5 KHZ. By doing this, there is reduction of bandwidth required for transmission and also reduction in network operational costs.

After filtering, the signal is sampled at a rate of 8000 samples per second. Each sample is then a quantized into one of the 128 possible levels [2]. Therefore, the number of pulse code modulation (PCM) code bits per sample can be calculated from the relation below:

$$q = \log_2 Q \dots\dots\dots(i)$$

where q = number of bits per sample; Q is the number of quantization levels.

Therefore, for voice communication, the number of bits for transmission is given by the following relation:

$$Q = \log_2 128 \dots\dots\dots(ii)$$

$$= 7 \text{ bits}$$

## 2. BASIC PCM TRANSMISSION RATE

In PCM communication, each voice signal sample is encoded into a 7 – bit codeword. A single synchronous bit is added at the end of the 7 voice data bits. Therefore, a PCM frame has a total of 8 bits or 1 byte. Figure 1 shows the structure of a PCM frame for voice communication. Whereas the synchronization data carries network signaling information, the voice data carries the actual user traffic that is to be relayed from the source to the destination.

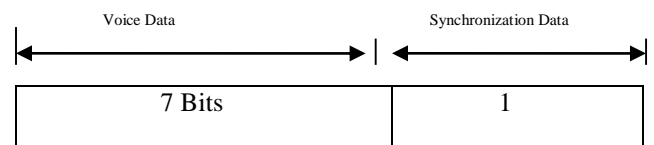

Figure 1: A PCM Voice Frame

According to [3], in voice communication, 8000 samples are taken per second. With each sample frame having 8 bits, then data speed for basic PCM is calculated as follows:

$$\text{Data Rate} = 8 \times 8000 \text{ bits.}$$

$$= 64000\text{bps or } 64\text{Kbps}$$

Data speed of 64Kbps is basic in data communication and is referred to as *Digital Stream Level 0* and abbreviated as DSØ.

## 3. PLESIOCHRONOUS DIGITAL HIERARCHY (PDH)

In their paper, [4] point out that in this system, low speed data streams are time division multiplexed (TDM) to form high speed data streams. The multiplexed data streams are nearly synchronous. The term plesiochronous refers to the fact that the data streams are nearly synchronous.

### 3.1 DS-1 CHANNEL

In North America and in other countries which have adopted the North American standard, the first level of data channel multiplexing is DS-1. Figure 2 shows how a DS-1 channel is formed.

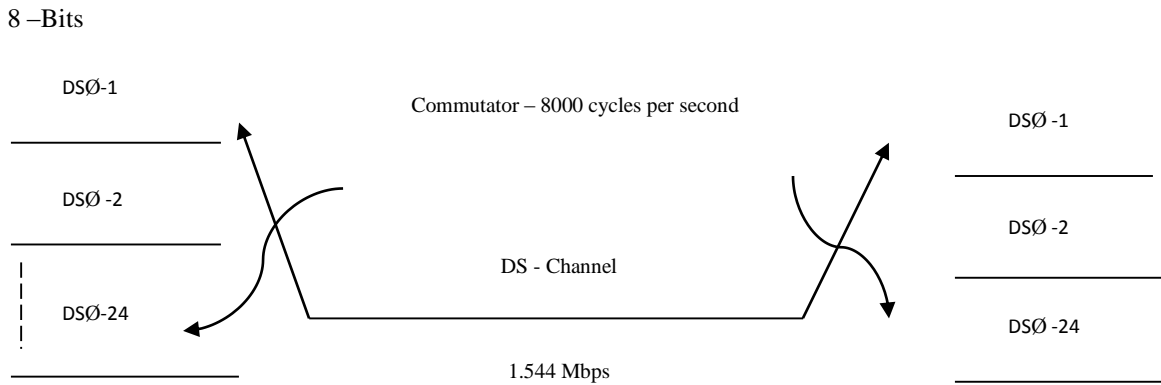

Figure 2: Formation of a DS-1 Channel

As shown in Figure 2, for each cycle, 8 bits are captured for each of the 24 channels. Therefore in a single cycle, the number of bits captured is:

$$\begin{aligned} \text{Number of captured bits} &= 8 \times 24 \\ &= 192 \text{ bits} \end{aligned}$$

At the end of a cycle, one frame synchronization bit is added. Therefore, in a single cycle, the number of bits for transmission is 193 bits. The data speed for the DS-1 channel can then be calculated as follows:

$$\begin{aligned} \text{Number of bits/frame} &= 193 \\ \text{Number of frames/ second} &= 8000 \\ \text{Therefore, bits/ second} &= 193 \times 8000 \\ &= 154400 \text{ bps Or } 1.544 \text{ Mbps} \end{aligned}$$

### 3.2 NORTH AMERICAN PDH SYSTEM

Using DS-1 as the level- 1, higher data speeds can be achieved by multiplexing to higher levels. In North American PDH, these levels are designated DS-2, DS-3 and DS-4. Table 1 shows the data speeds of these channels and the number of multiplexed lower data speed channels.

Figure 3 shows how the multiplexing is done in North American PDH system. The MUX represents the multiplexers while T1, T2 T3 and T4 are the carriers. The numbers below the data rates, 4, 7 and 6 represents the channel multiples needed to make up the following higher channel. For instance, from Figure 3, 24 voice channels are needed to make one T1. Similarly, 4 T1's are required to make up one T2. The commutator serves to sample the signals to be transmitted from the source to the destination. As Figure 2 demonstrates, the sampling is done at a rate of 8000 cycles per second. It involves navigating through all the 24 DS channels which is then followed by the combination process to produce a multiplexed signal that is then carried over a single transmission media.

Table 1: The North American PDH System Channels

Level	Voice Channel	DS1 Channels	Data Speed (Mbps)	Carrier Cable
DS0	1	N/A	0.064	N/A
DS-1	24	1	1.544	T1
DS-2	96	4	6.312	T2
DS-3	672	28(7 T2)	44.736	T3
DS-4	4032	168 (6 T3)	274.760	T4

It is important to note the fact that higher levels of multiplexing are not exact multiples of lower levels; but are nearly equal. For instance:

$$\frac{\text{DS-3 Data speed}}{\text{DS-2 Data speed}} = 44.736/6.312; = 7.087$$

DS-2 Data speed

This is not equal to 7 as alluded in table 1 and Figure 3. This is because more data is added to improve synchronization and the system is truly plesiochronous.

### 3.3 EUROPEAN PDH SYSTEM

In this system, 32 DS0 channels are TDM multiplexed to produce a data stream with a rate of 2048 Kbps or 2.048Mbps. The channel with this data rate is referred to as E1. This is the lowest level of multiplexing and higher data channels referred to as E2, E3 and E4 are obtained by further multiplexing. Figure 4 shows the structure of an E1 frame.

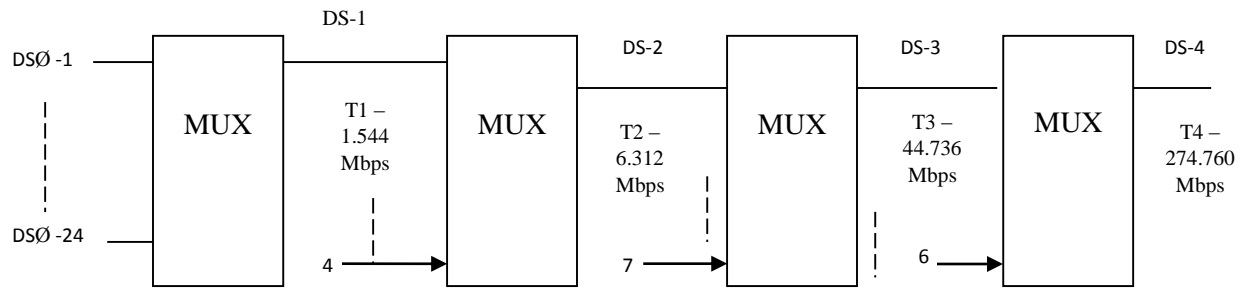

Figure 3: North American PDH System

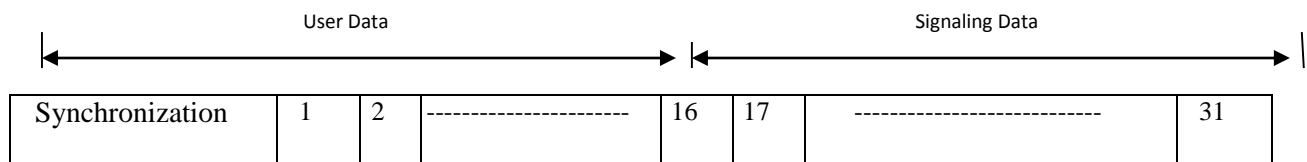

Figure 4: Structure of an E1 Frame

8- Bits

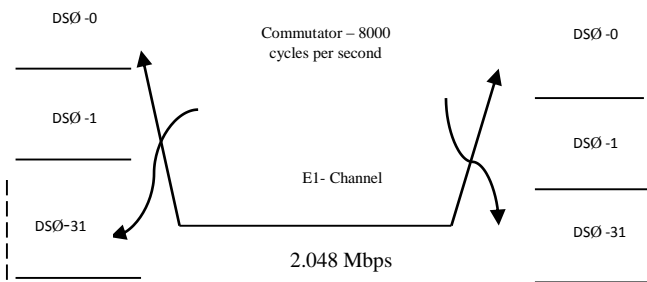

Figure 5: E1 Channel Formation

As can be seen in Figure 4, the first channel in the E1 is used for synchronization only. Therefore, in an E1 channel, only 30 channels are available for user data. The multiplexing scheme for an E1 channel is similar to the DS-1 and is given in Figure 5. The commutator similarly serves to sample the signals to be transmitted from the source to the destination. As Figure 2 demonstrates, the sampling is done at a rate of 8000 cycles per second as was the case for the DS-1 channels.

As shown in Figure 5, 8 bits are captured per sample. Therefore in one cycle, the number of bits captured is given by:

$$\begin{aligned} \text{Number of captured bits} &= 8 \text{ bits} \times 32 \text{ channels} \\ &= 256 \text{ bits.} \end{aligned}$$

Therefore, the data speed in an E1 channel can be calculated as follows:

$$\begin{aligned} \text{Number of bits / cycle} &= 256 \text{ bits} \\ \text{Number of cycles/ second} &= 8000 \end{aligned}$$

$$\begin{aligned} \text{Therefore, number of bits per second} &= 256 \times 8000 \\ &= 2048000 \end{aligned}$$

$$\begin{aligned} \text{Hence data speed} &= 2048000 \text{ bps} \\ &= 2.048 \text{ Mbps} \end{aligned}$$

The PDH system is based on the Consultative Committee on International Telephone and Telegraphy (CCITT). Table 2 shows the CCITT PDH system multiplexing, carriers and data channels.

Table 2: CCITT PDH System

Carrier Channel	Data Rate (Mbps)	DS0 Channels	Ex Multiples
DS0	0.064	1	N/A
E1	2.048	32	1 E1
E2	8.448	128	4 E1
E3	34.368	537	4 E2
E4	139.264	2176	4 3E3

Figure 6 that follows shows the multiplexing scheme of the European PDH. The E1, E2, E3 and E4 represent the carriers while the MUX represents the multiplexers. The numbers below the data rates gives the multiples of the current data rates make up the next higher level data rate.

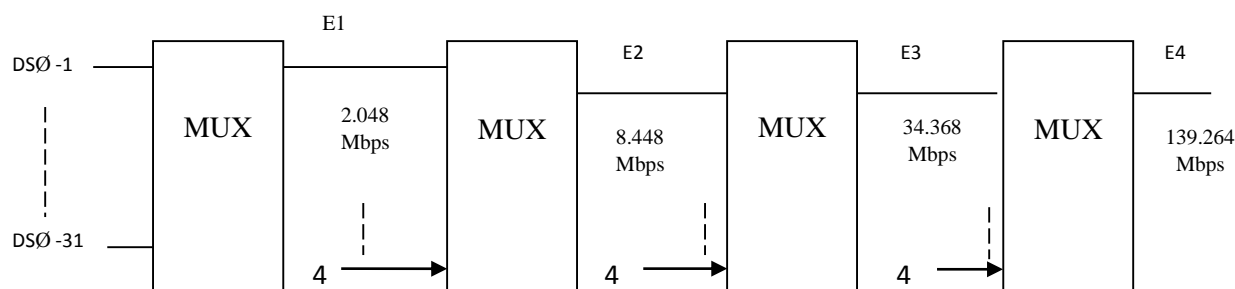

Figure 6: Structure of the European PDH System

The system is also plesionchronous, just like the North American system. This can be proved by trying to divide higher level data rate by the one immediately below it as shown below:

$$\frac{\text{E2 Data speed}}{\text{E1 Data speed}} = 8.448 / 2.048 = 4.125$$

**E1 Data speed**

Despite its wide deployment, the PDH system has a number of demerits. To start with, there is no fixed relationship that exists among the data rates at the different levels of the hierarchy. Therefore, the speed of each level is asynchronous with respect to each other.

Moreover, each multiplexer machine must be synchronized with other multiplexers in the system by sending a timing clock signal. The synchronization is not exact and is expensive. For CCITT, the allowable clock error is 1 in 10. Another glaring challenge is that only distinct set of fixed user data rates are available, namely  $N \cdot DS0$  where:

$$I = \langle n \leq 24 \text{ for North America (T1)} \rangle$$

$$I = \langle n \leq 30 \text{ for Europe (E1)} \rangle$$

**4. INTEGRATED SERVICE DIGITAL NETWORK**

According to [5], ISDN is a telecommunication network which has evolved from the classical public switched telephone network (PSTN). In the ISDN network, the subscriber can access both the voice telephony as well as data services because voice is digitized to data. Therefore in the ISDN network, voice and data traffic are integrated to form a seamless data communication network.

**4.1 THE ISDN SUBSCRIBER ACCESS NETWORK**

The subscriber access network (SAN) is decomposed into functional groups and reference points. Figure 7 shows the SAN reference configuration.

As shown, the configuration is split into subscriber premises installation, network operator installation, local exchange and digital transmission system (DTS). The subscriber premises installations represent the telecommunication equipment

owned by the customer, or leased by the customer from the service provider. The network operator installations represent the equipment owned by the service provider and which avail the required services to the customer.

The services performed by the various function groups are discussed below. The regions labeled R, S, T U and V are the ISDN reference points.

**a) Exchange Termination (ET):** - this equipment belongs to the network operator. Its function is to perform signaling insertion and extraction, frame alignment, alarm and fault indication.

**b) Line Termination (LT):** – this device performs the physical aspects of terminating the digital transmission system. The specific functions include feeding of power across the DTS to the customer premises installation, fault location through the transmission of loopback signals, generation and regeneration of baseband signals and conversion of on baseband code to another.

**c) Network Termination 1 (NT-1):** - This is the intermediary device between the network operators' equipment and the subscriber premises. Its main purpose is the termination of the DTS on the subscriber premises. In this capacity, it performs the following functions: transmission timing; feeding of power to the subscribers equipment; protection of network equipment against physical damage; cooperates with ET in providing fault-diagnosis; performing monitoring and maintenance of SAN.

**d) Network Termination 2 (NT-2):**- this equipment corresponds to the switching devices located on the subscriber's premises. The key function is multiplexing of multiple information streams. A private automatic branch exchange (PABX) is a NT-2 device.

**e) Terminal Equipment 1(TE-1):** - this is the subscriber terminal equipment whose functions are completely in conformity with ISDN specifications. An example is a digital telephone.

**f) Terminal equipment 2 (TE-2):** - this is the subscriber terminal equipment which is not in total conformity with the

ISDN specifications. A personal computer is an example of a TE-2 equipment.

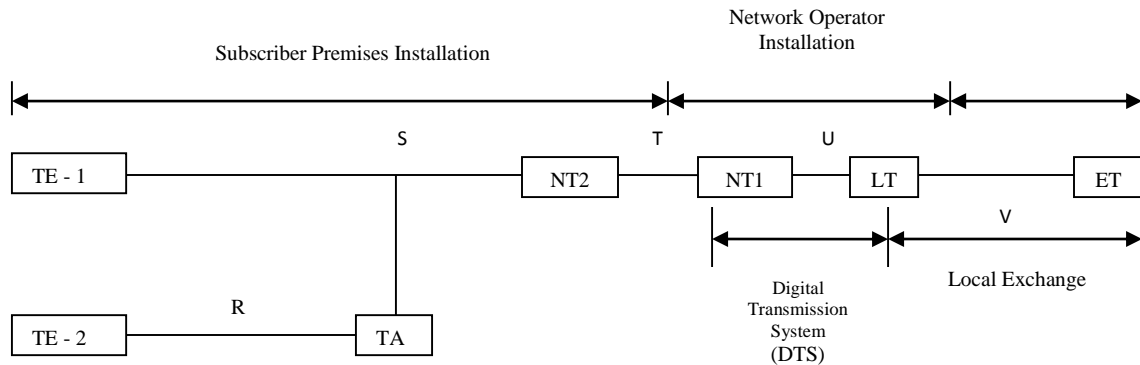

Figure 7: SAN Reference Configuration

**g) Terminal adapter (TA):-** this is the device used to adopt a TE-2 to ISDN specifications. A modem is an example of a TA equipment.

**h) Reference Points:-** these are the points between functional groups. For example, the T reference point lies between NT-1 and NT-2 groups.

4.2 USER NETWORK INTERFACE (UNI)

This reference point corresponds to the reference point T of the SAN configuration. At UNI, three types of access methods are available [6]:

**a) Basic Access:-** this is also called basic rate interface (BRI). This interface consists of 2B channels and 1 D channel. The channels are multiplexed. The data rate for this access is calculated as follows:

$$\begin{aligned} \text{User data} &= 2B \text{ Channels}; = 2 \times 64; = 128 \text{ Kbps} \\ \text{Signaling} &= 1D \text{ channel}; = 1 \times 16; = 16 \text{ Kbps} \\ \text{Overhead data} &= 48 \text{ Kbps} \\ \text{Total data rate} &= 192 \text{ Kbps.} \end{aligned}$$

In this access type, each B channel can be independently configured for either PCM voice data or for a non-ISDN device, such as personal computer [7]. BRI access is suitable for a typical home user, where 1 B channel can be used for telephone services and the other channel for internet access using a personal computer, using a modem.

**b) Primary Rate Access:-** this access is also called the primary rate interface (PRI). This access provides multiplexed channels up to the first level of multiplexing in the PDH digital hierarchy. The access structure is as follows:

**In the USA,**

$$\begin{aligned} \text{User data channels} &= 23 B \text{ channels}; = 23 \times 64; = 1472 \text{ Kbps} \\ \text{Signaling} &= 1 B; = 64 \text{ Kbps} \\ \text{Total throughput} &= 1536 \text{ Kbps} \\ \text{Synchronization} &= 8 \text{ Kbps} \\ \text{Total traffic} &= 1544 \text{ Kbps} \end{aligned}$$

**In Europe,**

$$\begin{aligned} \text{User data channels} &= 30 B \text{ channels}; = 30 \times 64; = 1920 \text{ Kbps} \\ \text{Signaling} &= 1 B; = 64 \text{ Kbps} \\ \text{Total throughput} &= 1536 \text{ Kbps} \\ \text{Synchronization} &= 1 B = 64 \text{ Kbps} \\ \text{Total traffic} &= 2048 \text{ Kbps} \end{aligned}$$

**c) Baseband Access:-** this refers to the access speeds beyond the primary rate. It is also called Broadband ISDN (B-ISDN).

**d) Narrow Band ISDN (N-ISDN):-** this refers to access rates below B-ISDN. Therefore BRI and PRI are N-ISDN technologies. Table 3 gives UNI rates and their application areas.

Table 3: UNI Rate and Applications

ISDN User Channel	Rate(Kbps)	Multiples of B	Carrier	Services
B	64	1	N/A	Voice, home PC
HQ	384	6	N/A	Audio broadcasting
H11	1536	24	T1	Slow TV scan, private WAN

H12	1920	30	E1	Slow TV scan, private WAN
H21	32768	512	E3	Composite videos
H22	44160	690	T3	Composite videos
H4	135,168	2112	E4	Colour TV, HDTV

For N-ISDN, it is only B channel that is used. However, for B-ISDN, H12, H21, H22 and H4 are used.

### 5. SYNCHRONOUS DIGITAL HIERARCHY (SDH)

In [8], a detailed discussion on the operations of PDH is provided. They note that the development of SDH was driven by the need to transport multiple PDH signals such as DS1, E1, DS3 and E3, along with other groups of multiplexed 64Kbps PCM voice traffic. In this scheme, data at the sending end is packed into a transport frame (Transport module) that is then synchronously transported across the user network interface (UNI). The frame format is based on the Synchronous Optical Network (SONET) developed by the T1 committee of the American National Institute (ANS T1.105) and T1.106. In SDH, all frames are constructed from a basic transfer frame known as Synchronous Transport Module level 1 (STM-1). Figure 8 shows the structure of an STM-1 frame.

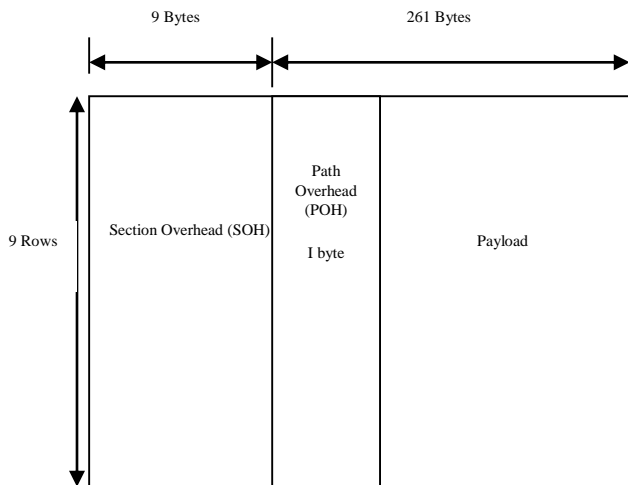

Figure 8: STM-1 Frame Structure

Figure 8 shows that an STM-1 frame has a total of 2340 (from  $270 \times 9 = 2340$ ) bytes of information, organized in a rectangular array of 9 rows and 270 columns. The first 9 columns of each array contains the section overhead (SOH), which consist of information needed to synchronize and demultiplexing the frame, performs error checking and carry out certain maintenance activities. The remaining 261 columns, referred to as the payload, carry the user data information and some additional overhead. Each frame is transmitted in 125  $\mu$ s,

resulting in 8000 frames per second (from  $1/0.000125$ ). Since each frame has  $2340 \times 8$  bits or 19440 bits, the resulting data rate is  $19440 \times 8000$  bps or 155.520 Mbps.

By confining the bytes contained in  $N$  STM-1s, higher level frames labeled STM-N are obtained that consists of a rectangular array of  $N \times 270$  columns and 9 rows, as shown in Figure 9.

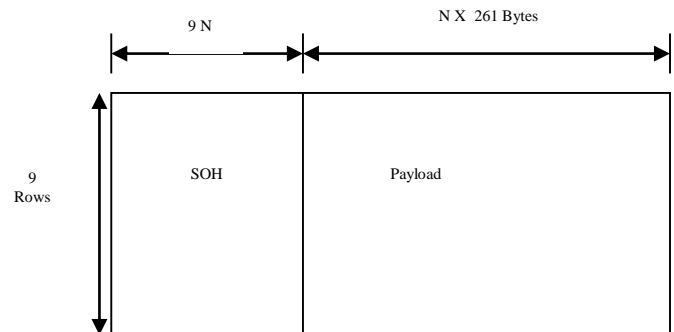

Figure 9: STM -N Frame

At a frame rate of 8000 frames /second, higher data speeds can be obtained. For example, for STM-4, data speed of  $4 \times 155.520$  or 622.08 Mbps can be achieved. Similarly, STM-256 systems are now available, with a data rate of  $256 \times 155.520$  or 39.813 Gbps. During transmission, the scan of an STM-N frame is done from left to right, then left to right of the next row, and finally a block is read.

### 6. ASYNCHRONOUS TRANSFER MODE (ATM)

In an ATM network, the payload of an STM-1 frame is broken into equal pieces called cells. Each cell may be used to carry information relating to any type of connection or application and asynchronously transmitted [9]. The data traffic is clustered into cells, where each cell consists of 53 bytes. A typical ATM cell is represented as shown in Figure 10.

The generic flow control (GFC), the virtual path identifier (VPI), the virtual channel identifier (VCI), the payload type indicator (PTI), the cell loss priority (CLP) and the header error check (HEC) all represent the ATM cell header and they just carry bits of information necessary for the efficient transfer of the user data traffic from the source to the destination.

The payload, on the other hand, represents the actual user traffic which is to be carried from the source to the destination. It is 48 bytes long, which translates to 384 bits of information. The header is 5 bytes long, translating to 40 bits of information. Therefore, for every 384 bits of user data transferred from the source to the destination, 40 bits are employed to accompany this payload. Its purpose is to ensure that this user traffic arrives safely with minimal losses. As shown in Figure 10, the ATM cell always is made up of a 5-byte header followed by a 48-byte payload. The header is used for network signaling while

the actual traffic is carried in the payload segment. Further, [9] explains that each of the six header elements performs varied functions that facilitate the entire communication process.

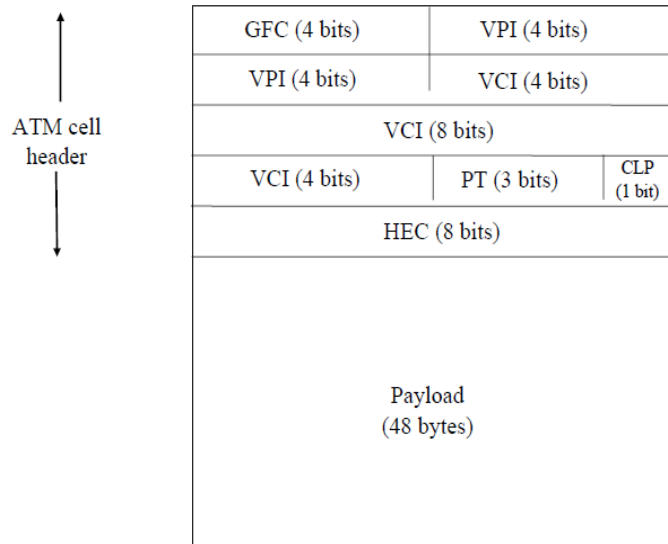

Figure 10: The Structure of an ATM Cell

**The Generic Flow Control (GFC):-** this field provides the User-Network Interface (UNI) 4 bits in which to agree multiplexing and flow control techniques among the cells of various ATM connections. In essence, the GFC contains the data required to control the volume of information from a particular source across the UNI to ensure a fair and equitable support of different services at the terminals of the cell [10]. The GFC protocol must be capable of ensuring that all terminals can access their assured capacities. This will be necessary for all constant bit rate (CBR) terminals such as voice, as well as those variable bit rate (VBR) terminals, which have an element of guaranteed capacity.

**The Virtual Path Identifier (VPI):-** is utilized to describe the virtual path for this specific cell. This field contains routing information, which is equivalent to an area code in a telephone system.

**The Virtual Channel Identifier (VCI):-** specifies the virtual channel within the described virtual path for this specific cell. The information in this field identifies the virtual cell destination. The VCI's which can be routed together are assigned the same VPI.

**The Payload Type Indicator (PTI):-** is a 3-bit field whose fields are utilized in varied ways. The first bit designates the type of ATM cell that follows. When the first bit is set to 0, this implies user data. However, when this bit is set to 1, this implies operations, administration and management data. The second bit specifies whether the cell experienced congestion in its journey from source to destination while the third bit is used

to show the last cell in a block of user ATM cells. Therefore in essence, this field identifies payload as either user or network information.

**The Cell Loss Priority (CLP):-** this field is a 1-bit field that is employed as a precedence pointer. Cells with the CLP bit set may be discarded when traffic inputs temporarily exceed the capacity of the network. For example, in the case of CLP=0; the cell has high priority and therefore sufficient network resources have to be allocated to it. In their regard, CBR applications have CLP=0, and VBR applications have CLP=1.

**Header Error Check (HEC):** this field is an 8-bit field that allows an ATM switch or ATM endpoint to correct a single-bit error or to detect multi-bit errors in the first four bytes of the ATM header. The information in this field protects the header section data, if error occurs during transmission, this field is used for error detection.

**Payload Field:-** this field contains the message to be transmitted. The message type is set at the PTI field in the header section.

## 7. FRAME RELAY

In their study, [11] explain that this technology provides telecommunication services that enable the cost-efficient data packet transmission for traffic traversing local area networks and terminals in a wide area network. It puts data in variable-size units, which are called frames. A typical frame relay (FR) set up is shown in Figure 11.

The DCE represent the data communication equipment while the DTE represent the data terminal equipment. The DTE may represent equipment such as desktop computers that provides the data that is to be transferred over the telecommunication channel. The DCE on the other hand may include routers and gateways that feed the service provider local loop with the user data. The frame relay network dedicates error-correction activities to the communicating end-points. The advantage of this is that it speeds up overall data transmission. In most of the services that it offers, the FR network avails a permanent virtual circuit (PVC). According to [12], this means that the FR customer gets a continuous dedicated connection and therefore he does not have to pay for full-time leased line connections. It is the responsibility of the service provider to determine the route each frame traverses from the source to the destination and he can therefore charge the customer based on network services usage.

The FR data packets can be transmitted over a fractional T1 or entire T-carrier system carriers, or E1 or whole E-carrier. The FR, in essence, complement and provides a mid-range service between ISDN's BRI, that provides bandwidth of 128 Kbps, and ATM, whose functionality is somewhat similar to Frame Relay but at data rates of from 155.520 Mbps to 622.080Mbps as already discusses in the sub-sections above.

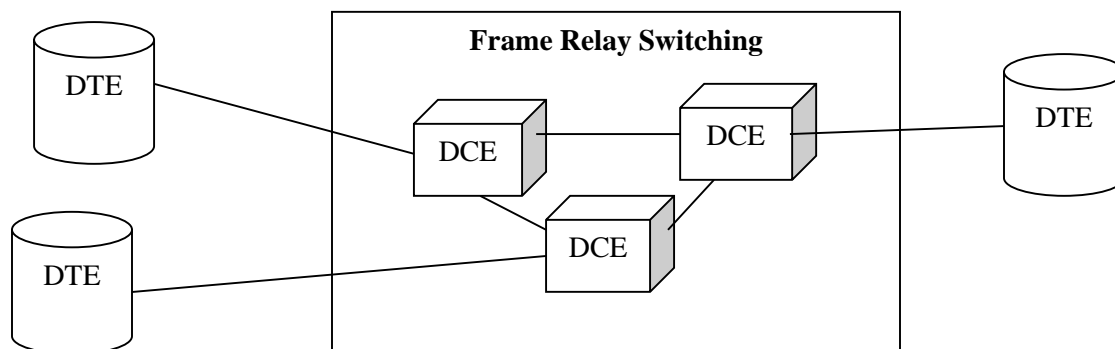

Figure 11: Frame Relay Network

## 8. DISCUSSIONS

The empirical analysis of the various clustered networks has provided a wealth of information that can be interpreted in a variety of ways. In this section, the analysis is extended but on the merits and setbacks perspectives of these technologies. In a Plesiochronous Digital Hierarchy (PDH), for instance, [4] noted that PDH is not flexible and is inefficient. The inflexibility roots from the fact that it is difficult in determining individual channels in a higher bit streams. This normally requires that multiplexing has to be done for the high bit rate channel down via all the multiplexing levels till the optimal rate is identified. This of course necessitates for more multiplexing costs and this makes it expensive.

In frame relay networks, the rates of discarding frames are high. Some of the reasons that may be attributed to this may include FCS errors; the throughput being greater than the committed information rate, there is transmission of too many frames per second, or network congestions [11]. In an ATM network, there are 5 bytes for every 48 bytes of payload, which means that the available bandwidth is not efficiently utilized. This is because the extra 5 bytes are used for network signaling purposes and does not carry the user traffic, which is the main reason for having the ATM cell in the first place.

Moreover, the network is inflexible from the view point that it cannot adjust the payload to higher levels to take advantage of high bandwidth channels such as fiber media [9]. From its structure, the maximum user data that can be carried by a single ATM cell is 48 bytes. This means that a cell ideally can carry less than 48 bytes, but not more than this value. Therefore, if the user data cannot fit in the current ATM cell, then it is carried forward and has to be carried by the next cell.

ISDN, just like ATM, is inflexible in that both the primary rate interface (PRI) and basic rate interface (BRI) has fixed data rates that they can convey. Whereas BRI's cut off data rate is 192Kbps, the cut off limit for PRI is 1.544 Mbps and 2.0448 Mbps for North America and Europe respectively. Moreover,

since it carries traffic of various types, chances of cross talk are high [7].

SDH is also nonflexible since it limits the payload to 261 bytes, which means that higher data rates can only be expressed as multiples of this value. Another point is that SONET and SDH have a restricted number of architectures defined for their utilization.

## 9. CONCLUSIONS

Most of the network traffic clustering mechanisms were designed during a time when the available transmission media offered limited bandwidths. However, due to the current increased bandwidth being offered by transmission media such as fiber optic cables, it is clear that the above technologies cannot easily scale to utilize this bandwidth in the most effective way. It is also important to note that most of the technologies involve heavy usage of signaling data that leads to bandwidth under-utilization since the bandwidth used for signaling data exchange could be used effectively to carry user payload. An ideal clustering mechanism should be adaptive in nature, such that more bytes can be carried when presented with a transmission media that has a higher bandwidth. On the same breadth, the clustering mechanism should be able to scale down the transmissions gracefully when operating in transmission channels that offer limited bandwidth. Moreover, the clustering technique should also be able to adjust to the prevailing network conditions. For example, when many stations are sending packets in the shared medium, the available bandwidth is drastically reduced compared to when a few stations are transmitting data. A clustering algorithm needs to regulate itself to mimic these network situations. The idea that higher levels of the transmission rates can only be expressed as multiples of lower levels means that the transmission rates drop catastrophically when low bandwidth media are to be traversed. This is counter-productive as it will severely interfere with the ongoing communications. This is more so evident with video streaming, which is highly sensitive to any form of delay or jitter. A need therefore arises for the development of efficient clustering techniques which can limit signaling information



exchange and be able to scale well to optimize the usage of high bandwidth communication channels as well as low bandwidth channels.

#### REFERENCES

- [1] Horak, R., "Telecommunications and Data Communications Handbook", Wiley-Interscience. p. 476, (2007).
- [2] Valdar, A., "Understanding Telecommunications Networks", (2006).
- [3] Niek D., "Deutsche Telekom - 100% IP by 2018", (2014).
- [4] Olabenjo B., Salim M., "A review of Plesiochronous Digital Hierarchy (PDH) and Synchronous Digital Hierarchy (SDH)", International Journal of Scientific Research Engineering & Technology (IJSRET), (2014).
- [5] Neuhetzki T., "Network Termination for ISDN Primary rate Access", (2014).
- [6] Ayanoglu, Ender, Akar, Nail. "B-ISDN (Broadband Integrated Services Digital Network)", Center for Pervasive Communications and Computing, UC Irvine. (2011).
- [7] AT&T Florida, "Integrated Services Digital Network (ISDN)", (2016).
- [8] Tozer, E., Paul J., "Synchronous Digital Hierarchy (SDH)", Broadcast Engineer's Reference Book, Focal Press. p. 97, (2004).
- [9] Mahesh G., "ATM Cell Format & ATM Header", Advance Computer Network, (2015).
- [10] Neelakanta, P., "A Textbook on ATM Telecommunications, Principles and implementation", CRC Press, (2000).
- [11] Malis, Andrew G. "Frame Relay Fragmentation Implementation ", (2016)
- [12] Steve G., Peter L., Sean Y., "Frame Relay Testing and Training", (2014).