

SECTION A: 10 Marks (Each question carries 1 Mark)

QUESTION ONE (10 Marks)

a) Define the following as used in engineering surveying (5 Marks)

- i. Departure
- ii. Latitude
- iii. Reduced bearing
- iv. Station Mark
- v. Signal

b) The diagram below shows parts of a survey instrument which can be used in traversing survey. Name the parts listed below

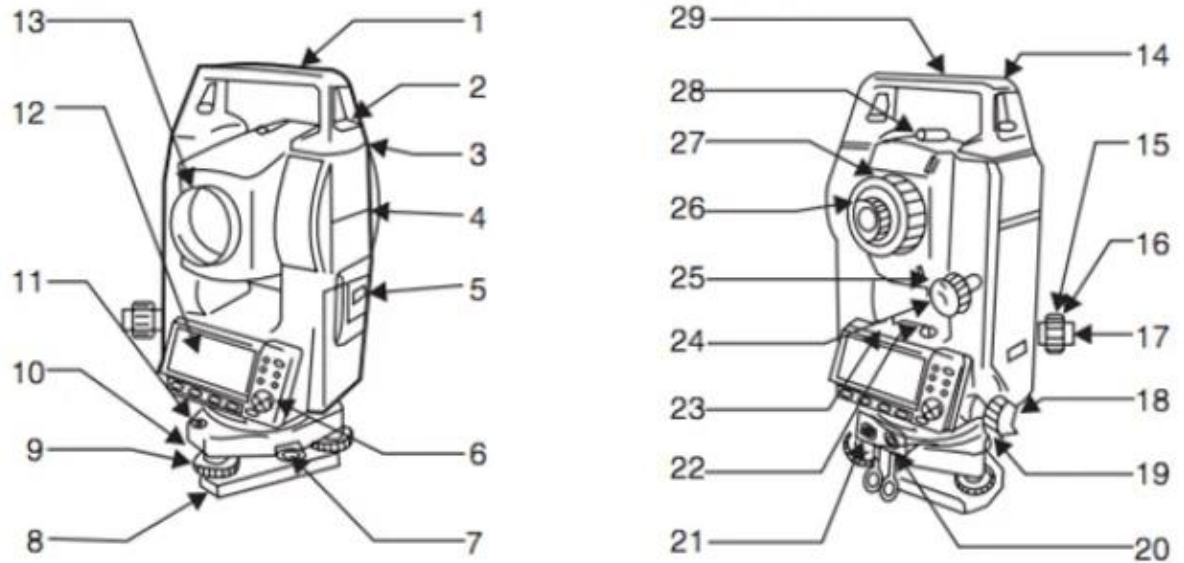

item	Part No	Name of Part
i	1	
ii	8	
iii	9	
iv	26	
v	27	

SECTION B: (20 Marks)

Attempt all questions in this section. Answers to questions in this section must be written in the spaces provided. Answers must be precise and concise.

QUESTION TWO (20 Marks)

- a) Differentiate between Triangulation and trilateration in engineering surveying practice
(5 Marks)
- i. Triangulation
 - ii. Trilateration
- b) In triangulation or trilateration, the surveyor takes measurements between stations which are widely spaced which could be even 50km. Explain how the surveyors ensure that the line of sight is not obstructed and that the stations are clearly visible to ensure accurate readings. **(5 Marks)**
- c) Outline the principle of triangulation **(5.5 Marks)**
- d) With the aid of simple illustrative diagrams, distinguish amongst the following types of horizontal curves **(4.5 Marks)**
- i. **Simple curve**
 - ii. **Compound curve**
 - iii. **Reverse curve**

SECTION C: (40 Marks)

Answer any two (2) questions from this section. Each question carries 20 Marks

QUESTION THREE (20 Marks)

- a) Depending on how the errors occur, arise or behave, three **types of errors** can be identified as enumerated below. Briefly discuss these error types clearly covering description of how they arise, nature of behavior and how to reduce or prevent. **(12 Marks)**
- i. Mistakes/blunders
 - ii. Systematic errors
 - iii. Random Errors
- b) The diagram below shows the design level of a dyke which is to be constructed at a point along the bank of river Yala in Nyadorera, in Siaya County. Using a nearby bench mark the surveyor has set the instrument as shown. Show how you can prepare a stake to assist the construction team in constructing the embankment. Include a sketch of the stake with the required levels marked on it. **(8 Marks)**

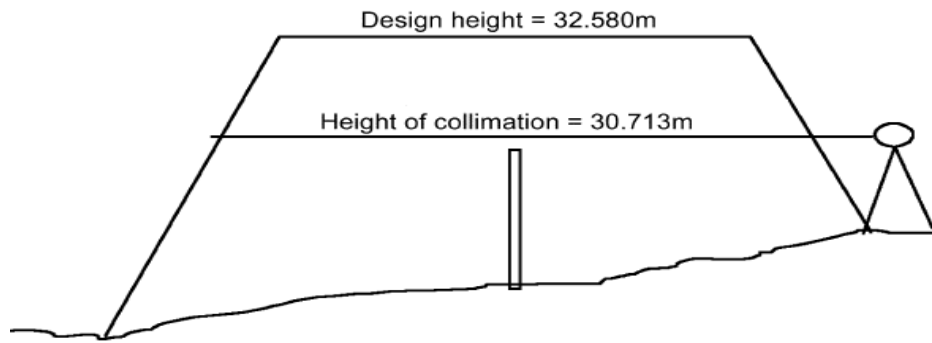

QUESTION FOUR (20 Marks)

Below you are given three survey stations P, Q and R. These stations lie on a part of an open traverse route. The traverse survey moves from the direction of P to R. The Horizontal angle at P has been measured and you are required to measure the horizontal angle at Q. Assume you have a digital theodolite.

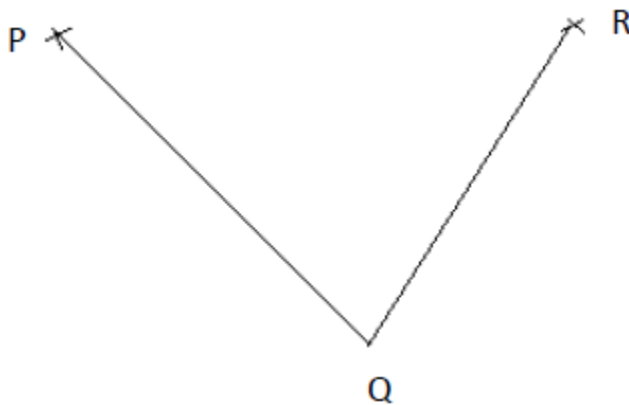

- a) Clearly and briefly, using the field record book provided below, outline the procedure involved; step by step action showing action done and how recording on the booking sheet done where necessary. Make use of either column number and row number to specify entry in the table. For example the reading of 300° is recorded in column **3** line **1**. **(15 Marks)**

	1	2	3	4	5
	Observation station	Target station	Face reading Left	Face reading Right	Accepted mean angle
1			300°		
2					
3					
4					
5					

6					
7					

b) Assuming from section a) above you have obtained the reading below in the order of which they were measured.

25° 30' 00'', 90° 55' 00'', 205° 30' 00'' and 270° 55' 00''

Record the readings in the field record book given and calculate the mean angle

(5 Marks)

Observation station	Target station	Face reading	Left	Face reading	Right	Accepted angle	mean

QUESTION FIVE (20 Marks)

The figure below shows an open traverse route which started on a known line and ended on a known line. The clockwise traverse angles measured are given in table Q5. The know bearings of lines BA and DC are 204° 11' 05'' and 02° 10' 47'' respectively. Compute all the forward bearings (azimuths) of the lines involved in the survey from the traverse angles. In case there is an error detected in the computed bearings remove the error through any suitable correction procedure. Use the tables provided in answering the question

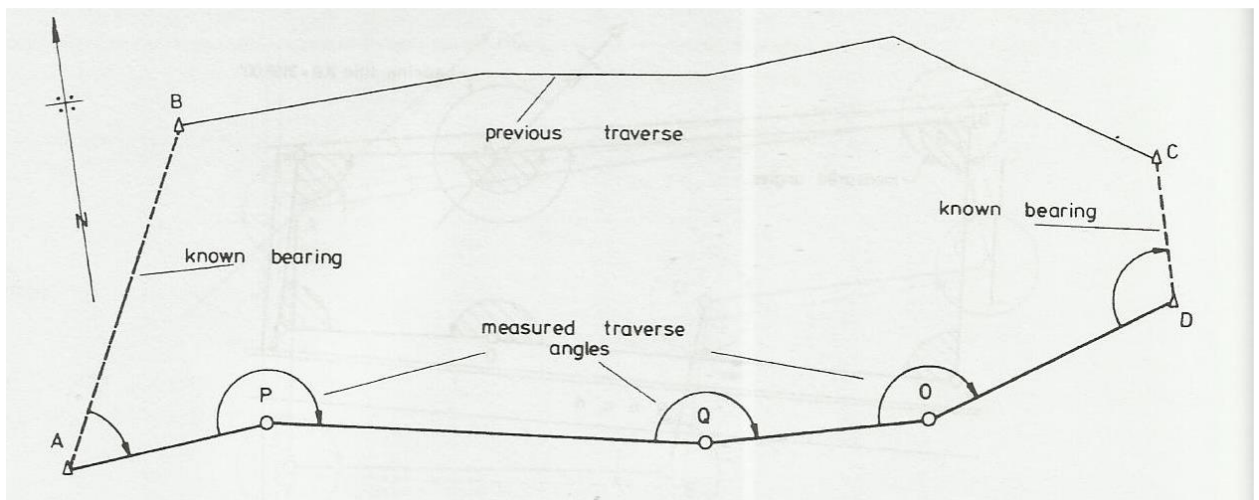

Fig Q5: Open traverse surveying

Table Q5.1: Traverse angles

Angle	BAP	APQ	PQO	QOD	ODC
Size measured	72° 39' 42''	187° 40' 12''	169° 23' 47''	161° 58' 20''	106° 17' 21''

Table Q5.2: Computed bearing

Line	Back bearing	Traverse angle	Forward bearing

Table Q5.3: Correction of computed bearings

Line	Uncorrected bearing	Correction	Corrected bearing

QUESTION SIX (20 Marks)

The figure and accompanying table give information of a traverse survey undertaken for road construction. The coordinates of station A in the local system are defined to be Easting 1000.000 metres and Northing 2000.00 metres. The coordinates of F have been previously calculated by other surveys to be Easting 1558.27 metres and Northing 2253.93 metres. The known initial bearing from A to B is $45^\circ 10' 10''$.

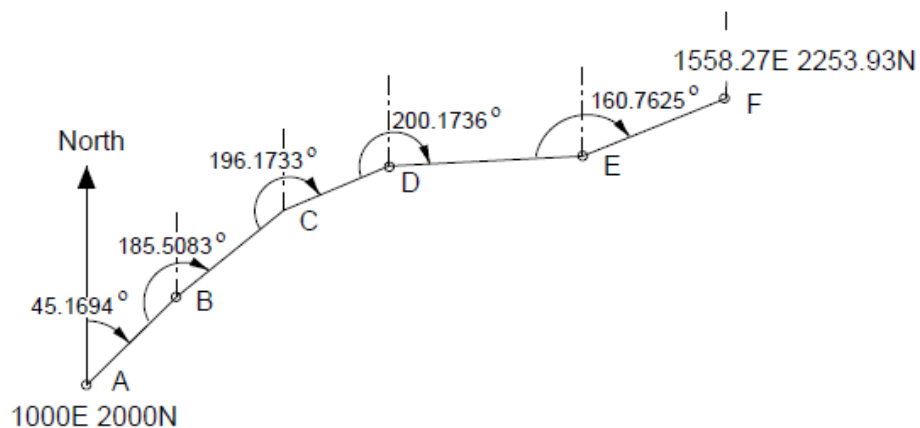

Station	Traverse leg	Measured Clockwise angle			Azimuth		
		deg	min	sec	deg	min	sec
A	-	-	-	-	-	-	-
B	110.45	185	30	30	45	10	10
C	121.33	196	10	24			
D	99.86	200	10	25			
E	169.27	160	45	45			
F	135.26						

- Use appropriate table to calculate the azimuths of the traverse legs
- Using the azimuths computed and other given information, calculate the coordinates of the traverse stations
- Check accuracy of the traverse and adjust if necessary