



JARAMOGI OGINGA ODINGA UNIVERSITY OF SCIENCE AND TECHNOLOGY
SCHOOL OF INFORMATICS AND INNOVATIVE SYSTEMS
DEPARTMENT OF INFORMATION SYSTEMS AND TECHNOLOGY
UNIVERSITY EXAMINATION FOR THE DEGREE OF
BACHELOR OF SCIENCE IN BUSINESS INFORMATION SYSTEMS
3RD YEAR, 2ND SEMESTER 2024/2025 ACADEMIC YEAR
MAIN CAMPUS
QUESTION PAPER

COURSE CODE: ITB 2310

COURSE TITLE: BUSINESS PROCESS MODELLING AND WORKFLOWS

EXAM VENUE: LAB 12

STREAM:

DATE: 25/4/2025

EXAM SESSION: 9.00-11.00AM

TIME: 2.00 HOURS

INSTRUCTIONS

- 1. Answer QUESTION ONE (Compulsory) and ANY other TWO questions**
- 2. Candidates are advised not to write on the question paper**
- 3. Candidates must hand in their answer booklets to the invigilator while in the examination room**
- 4. No mobile devices (e.g. laptops, phones. e.t.c.) are allowed into the Examination Room**

QUESTION ONE

(30 MARKS)

- a) Each organization—be it a governmental agency, a non-profit organization, or an enterprise—has to manage a number of processes. What is a business process? Give 4 typical examples of processes that can be found in most organizations. (6 Marks)
- b) Define the following: (6 Marks)
- i) Workflows
 - ii) human interaction workflows
 - iii) A single-application workflow
- c) Using a well labeled diagram describe the Ingredients of a business process and their relations. (10 Marks).
- d) The aim of a process architecture is to provide a representation of the processes that exist in an organization. One of the most influential categorization schemes is Porter's Value Chain model. Considering this model discuss the Components of a Process Architecture. (8 Marks)

QUESTION TWO

(20 MARKS)

- a) Model the following fragment of a business process for assessing loan applications (loan origination process).
- Once a loan application has been approved by the loan provider, an acceptance pack is prepared and sent to the customer. The acceptance pack includes a repayment schedule which the customer needs to agree upon by sending the signed documents back to the loan provider. The latter then verifies the repayment agreement: if the applicant disagreed with the repayment schedule, the loan provider cancels the application; if the applicant agreed, the loan provider approves the application. In either case, the process completes with the loan provider notifying the applicant of the application status. (10 Marks)
- b) When modeling a business process, we need to keep in mind the specific purpose and target audience for which we are creating the model. Discuss the two main purposes for process modeling. (4 Marks)
- c) Activities and events may not necessarily be performed sequentially. Explain the gateways used for branching and merging during modeling. (6 Marks)

QUESTION THREE**(20 MARKS)**

- a) What are the seven Process Modeling Guidelines (7PMG) (7 Marks)
- b) Explain the three process perspectives of control flow, data, and resources (9 Marks)
- c) There are various tools for creating business process models, give an overview of such tools. (4 Marks)

QUESTION FOUR**(20 MARKS)**

- a) Discuss the most important workflow data patterns regarding data visibility. (8 Marks)
- b) In a 2009 posting on LinkedIn, the director of Walgreens, an online pharmacy, asks what the common pitfalls are when implementing a workflow management system. A consultant at Microsoft answers as follows:
It's really all about people buying in to the system. The general tendency of people is that they don't like change, even if they say they do. Even if their current processes are very inefficient, they know how it works. So, when you introduce something that changes their world (with a workflow management system), they'll be very apprehensive. Also, the more the system changes how they do their job, the more resistance you'll get. Then it becomes an issue of how you gathered your business requirements. Chances are that due to misunderstandings the requirements will be different than expectations of how things should get done.
Explain whether you think this explanation relates to a technical or an organizational challenge. (12 Marks)

QUESTION FIVE

(20 MARKS)

a) Find the bugs...

(8 Marks)

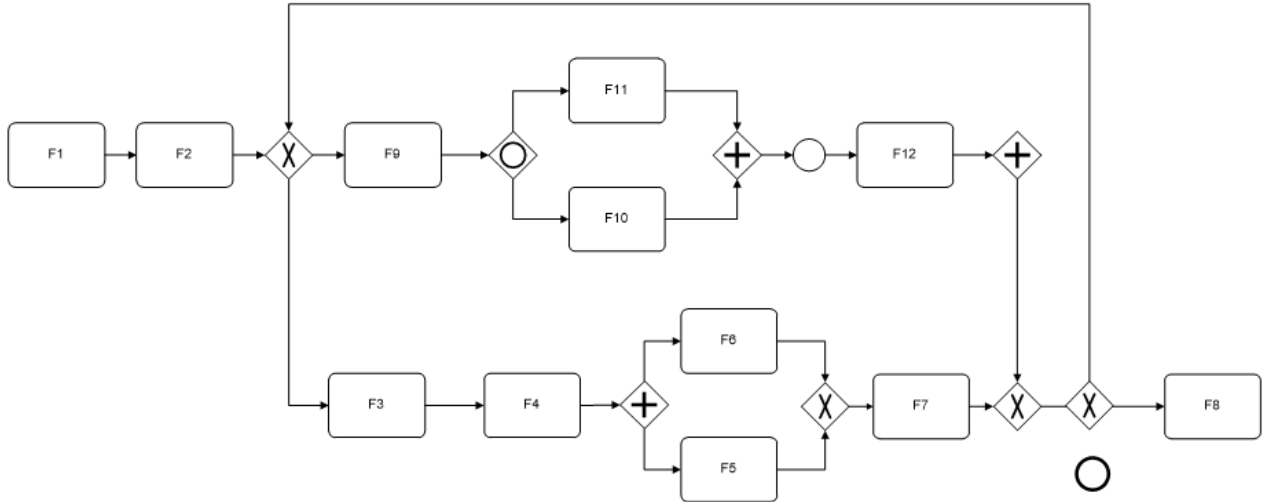

b) Model the following process fragment.

(12 Marks)

The order-to-cash process is carried out by a seller's organization which includes two departments: the Sales department and the Warehouse & Distribution department.

The purchase order received by the Sales department has to be checked against the stock. This is done via an ERP module within the Warehouse & Distribution department. If the purchase order is confirmed, the Warehouse & Distribution department ships the goods. Meantime, the Sales department emits the invoice. The process concludes with the order being archived by the Sales department.