



JARAMOGI OGINGA ODINGA UNIVERSITY OF SCIENCE AND TECHNOLOGY

SCHOOL OF INFORMATICS AND INNOVATIVE SYSTEMS

**UNIVERSITY EXAMINATION FOR THE DEGREE OF BACHELOR SCIENCE IN
SECURITY AND FORENICS**

2nd YEAR 2nd SEMESTER 2022/2023 ACADEMIC YEAR

MAIN CAMPUS

COURSE CODE: ITB 2204

COURSE TITLE: INFORMATION SYSTEM AND NETWORKING LAB

EXAM VENUE:

STREAM:

DATE:

EXAM SESSION:

TIME: 2.00 HOURS

INSTRUCTIONS:

- 1. Answer Question 1 (Compulsory) and ANY other two questions**
- 2. Candidates are advised not to write on the question paper**
- 3. Candidates must hand in their answer booklets to the invigilator while in the examination room**

QUESTION 1

- a) What inefficiencies were associated with Hub as a network? (3marks)
- b) Distinguish between a passive hub and active hub? (2marks)
- c) What is contained within the switch that make it intelligent? (2marks)
- d) What role does a subnet mask in network addressing? (2 marks)
- e) What two pieces of information are provided when you look at an IP ADDRESS? (2marks)
- f) State the respective private range A, B and C IP addresses? (3marks)
- g) How many sets of octates are responsible for the host part in Class A, B and C IP addresses? (3marks)
- h) Why is a Private IP address referred to non-routable? (2marks)
- i) What is a default gateway? (2marks)
- j) What role does a default gateway play in a network? (2marks)
- k) What is a distributed computing system? Why are they gaining popularity? (4marks)
- l) Why are WAN generally slower than LAN`s (2marks)
- m) What do you understand by the term DHCP scope (1mark)

QUESTION 2

- a) Identify basic elements of an information system and purpose of each (10 Marks).
- b) Distinguish between a centralized and decentralized network model (10marks)

QUESTION 3

- a. As a consultant in network design you are requested by the ICT Director to design a secure network for JOOUST with aid of a diagram show your proposed design. **Note:** use the class C addressing scheme for these purpose and Let the network have at least four subnets
(10marks)
- b. Briefly explain at least 4 advantages associated with subnetting a network (8marks)
- c. Distinguish between Network Address Translation (NAT) and Port Address Translation (PAT). (2mark)

QUESTION 4

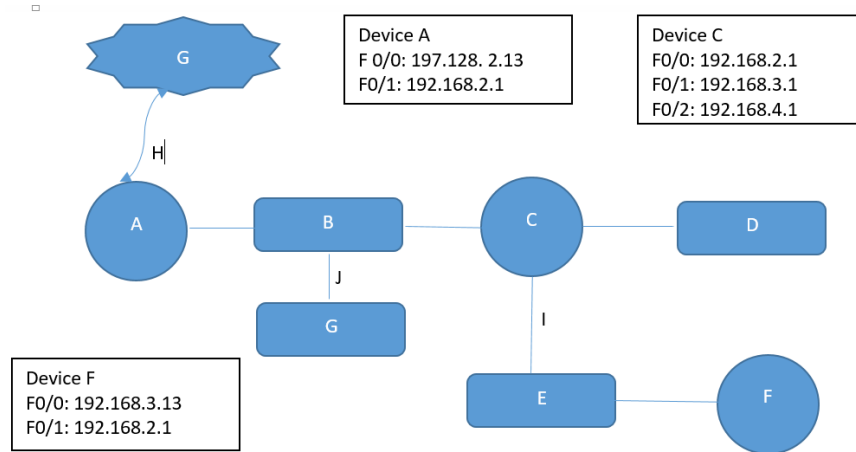

- Name devices A B C **(3marks)**
- What type of cabling are H I and J **(3marks)**
- What will be the IP address of a node attached to device D G and F **(3marks)**
- Do you notice anything wrong with the network diagram if so what is it? What problem would it cause? And what remedy would you apply **(3marks)**
- Would a Node attached to Network F be able to send packet through to G explain your answer **(2marks)**
- You are the administrator for a network that uses TCP/IP. You are using a single registered Class C network address. You want to continue to use it because many of your systems are accessed from outside sources, but you also want to create more networks so that you can more effectively manage traffic and security. Which strategies would help you achieve this? **(2marks)**
- A user on your network can send data packets within the local subnet but cannot send packets beyond the local subnet. What is likely the problem? **(1mark)**
- Which term describes the process of using parts of the node address range of an IP address as the network ID? **(1mark)**
- You are tasked with specifying a way to connect two buildings across a parking lot. The distance between the two buildings is 78 meters. An underground wiring duct exists between the two buildings; although, there are concerns about using it because it also houses high-voltage electrical cables. The budget for the project is tight, but your manager still wants you to specify the most suitable solution. Which cable type would

you recommend?
(1mark)

QUESTION 5

- a) Explain the functions of the following command **(8marks)**
- b) Is it True or False to say that VLANs enable you to create multiple broadcast domains on a single switch? Explain your answer. **(2marks)**
- c) Define Scopes, Lease and Reservation in relation to DHCP. **(6marks)**
- d) Distinguish between Network Address Translation (NAT) and Port Address Translation (PAT) **(4marks)**