



**JARAMOGI OGINGA ODINGA UNIVERSITY OF SCIENCE AND TECHNOLOGY  
SCHOOL OF SPATIAL PLANNING AND NATURAL RESOURCE MANAGEMENT  
UNIVERSITY EXAMINATION FOR THE DEGREE OF BACHELOR OF ARTS IN  
SPATIAL PLANNING  
SEMESTER 2021/2022 ACADEMIC YEAR**

**CENTRE: MAIN CAMPUS**

---

**COURSE CODE: PPB 1203**

**COURSE TITLE: PLANNING PRESENTATION TECHNIQUES**

**EXAM VENUE: STREAM: SPATIAL PLANNING**

**DATE: EXAM SESSION:**

**TIME: 2 HOURS**

---

**Instructions:**

- 1. Answer question 1 ( compulsory ) and ANY other 2 questions.**
- 2. Candidates are advised not to write on the question paper.**
- 3. Candidates must hand in their answer booklets to the invigilator while in the examination room.**

### QUESTION ONE (30 MARKS)

- a) Discuss the application of planning presentation techniques in your professional field? (6 Marks)
- b) Explain how you can effectively use the following drawing instruments in the production of an engineering drawing
- a) Tee Square (2 Marks)
  - b) Drawing Table (2 Marks)
  - c) Adjustable Set Square (3 Marks)
- c) A *scale* is always presented in every technical and engineering drawing
- a) Explain the purpose of a scale in a drawing (3 Marks)
  - b) Calculate the corresponding plan/paper distance for a ground distance of 1.80km for a plan whose scale is 1:2500. (4 Marks)
- d) By use of illustrations, differentiate between pictorial and orthographic projections as used in planning presentation techniques and technical drawing. (10 Marks)

### QUESTION TWO (20 MARKS)

- a) Construct a triangle given Perimeter,  $P=20\text{cm}$ , Altitude,  $L=4\text{cm}$  and vertical angle,  $\Theta=40^\circ$  (7 Marks)
- b) Construct a hexagon within a circle of diameter 6cm. (7 Marks)
- c) Draw a regular heptagon with sides 38mm long. (6 Marks)

### QUESTION THREE (20 MARKS)

- a) Use technical drawing equipment to illustrate one point and two point perspective projections. (10 marks)
- b) Draw to scale a floor plan of a VIP latrine. (10 marks)

### QUESTION FOUR (20 MARKS)

Figure 1 below is an isometric projection of an object. Draw the same figure in oblique projection to a scale of 1:5. (**Dimensions are in centimetres**)

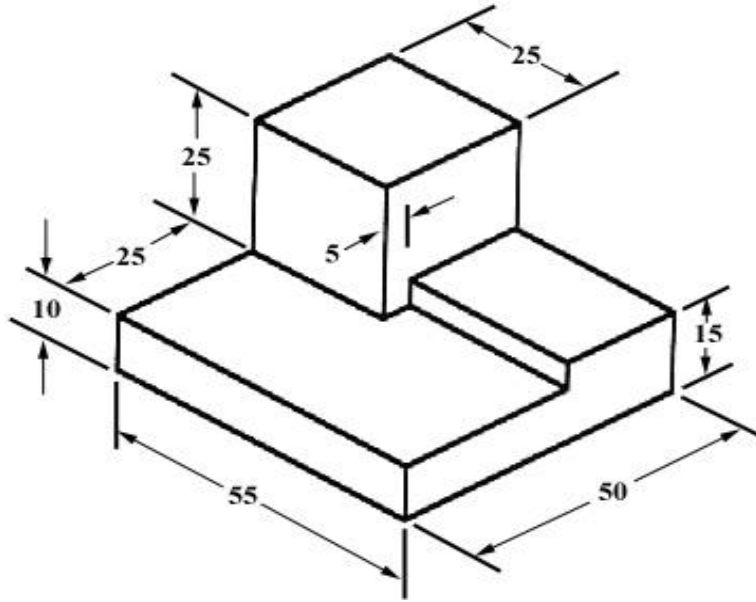

Fig 1.

**QUESTION FIVE (20 MARKS)**

Use an appropriate scale to draw the following figure

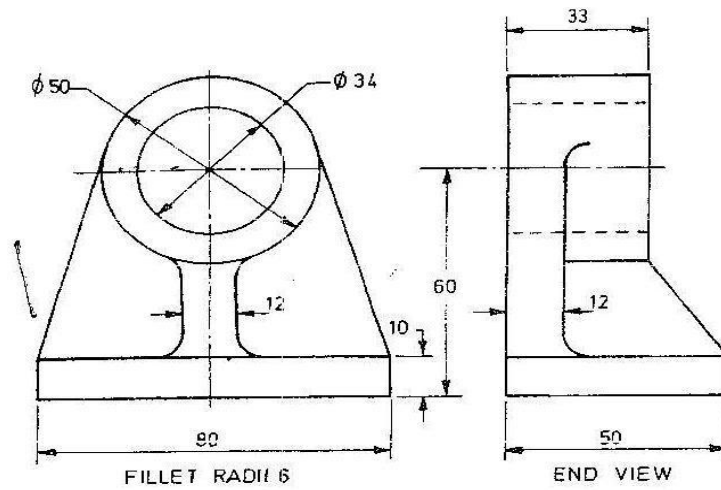

Figure 2