



JARAMOGI OGINGA ODINGA UNIVERSITY OF SCIENCE AND TECHNOLOGY

SCHOOL OF ENGINEERING AND TECHNOLOGY

UNIVERSITY EXAMINATIONS FOR THE DEGREE OF SCIENCE IN:

RENEWABLE ENERGY TECHNOLOGY AND MANAGEMENT

2ND YEAR 1ST SEMESTER 2015/2016 ACADEMIC YEAR

CENTRE: MAIN CAMPUS

COURSE CODE: TET 3212

COURSE TITLE: SOLID MECHANICS

EXAM VENUE: W/S

STREAM: BSc RE. ENERGY TECH AND MGT

DATE: 25/4/16

EXAM SESSION: 9.00 – 11.00 AM

TIME: 2 HOURS

Instructions

- 1. Answer Question 1 (compulsory) and ANY other two questions**
- 2. Candidates are advised not to write on question paper.**
- 3. Candidates must hand in their answer booklets to the invigilator while in the examination room**

QUESTION ONE

- i. Differentiate between a *deformable* body and a *rigid* body as used in solid mechanics (**4Marks**)
- ii. As a student undertaking a course in Renewable Energy, Technology and Management, explain how you will be able to apply the knowledge of this subject in future (**3Marks**)
- iii. Solid mechanics basically deals with the study of the distribution of internal forces (stresses) and the stability and deformation of various elements of structures and machines subjected to externally applied forces. Briefly explain this statement (**5 Marks**)
- iv. Distinguish between live loads and dead loads as concern structural loads (**6 Marks**)
- v. Briefly describe the following properties of structural materials (**MARKS 8**)
 - a) Strength
 - b) Hardness
 - c) Toughness
 - d) Ductility
- vi. Briefly explain the following (**MARKS 5**)
 - a) Torque
 - b) Torsion

QUESTION TWO

- a) Briefly explain the meaning of the following (**6Marks**)
 - i. Shaft
 - ii. Torsional member
 - iii. A couple
- b) In a power transmission system of a motor vehicle using gears, the arrangement is such that a driver gear is much smaller than the driven gear. Explain what happens to speed and torque from input to output shafts. You may use also diagrams to illustrate your answer (**6Marks**)
- c) A steel shaft of solid circular section has to transmit 300kW at 200 rpm. The maximum shear stress is not to exceed 50 MPa and the angle of twist not more than 1° in a length of 3 m. Select a suitable diameter if the modulus of rigidity $G = 8.4 \times 10^4 \text{ N/mm}^2$. (**8Marks**)

QUESTION THREE

- i. A railway line is laid so that there is no stress at 10°C. Compute
- The stress in the rails at 50 °C if there is no allowance for expansion,
 - The stress in the rails at 50 °C if the expansion allowance is 10mm;
 - The expansion allowance required if the stress is to be zero at 50 °C,
 - The maximum temperature if there should be no stress in the rails for an expansion allowance of 15mm.

The rails are 25m long. The modulus of elasticity is 2×10^5 MPa and the coefficient of linear expansion of rail steel is $12.5 \times 10^{-6}/^\circ\text{C}$
(10 MARKS)

- ii. A tensile test was conducted on a mild steel bar. The following data was obtained from the test
- Diameter of the bar = 30mm
 - Gauge length = 200mm
 - Load at elastic limit = 250kN
 - Maximum load = 360kN
 - Extension at a load of 155kN = 0.22mm
 - Total extension = 61mm
 - Diameter of the rod at failure = 22.45mm

Determine

(10 MARKS)

- The Young's modulus
- The stress at elastic limit
- Percentage elongation
- Percent reduction in area

QUESTION FOUR

- i. Distinguish between elasticity and plasticity and show how each of these material properties can be used in engineering **(5MARKS)**
- ii. A member is formed by connecting a steel bar to an aluminium bar end to end as shown. Calculate the thrust P so that the total decrease in length is 0.25mm. $E_s = 2 \times 10^5$ MPa and $E_a = 0.7 \times 10^5$ MPa **(5 Marks)**

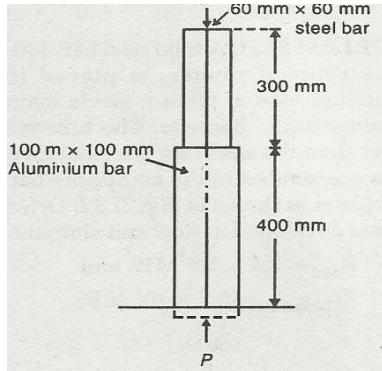

- iii. A solid steel bar, 480mm long and 60mm diameter, is placed inside aluminium tube of 65mm inside diameter and 90mm outside diameter. The tube is 0.12mm longer than the steel bar. An axial thrust of 500kN is transmitted to the composite bar through rigid plates as shown. Determine the stresses developed in the steel and aluminium. $E_s = 2.1 \times 10^5$ MPa and $E_{al} = 0.7 \times 10^5$ MPa
(6Marks)

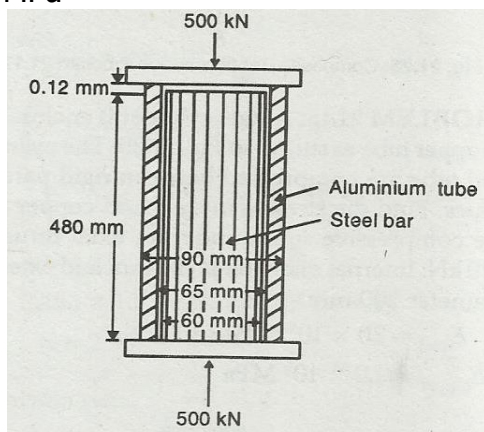

- iv. Draw a typical stress - strain curve for a ductile material and name all the key points
(4 MARKS)

QUESTION FIVE

- Explain what you understand by the term *Poisson's ratio* as relates to the deformation of a structural member
(5 MARKS)
- Two parts of a tie-rod are connected by a bolt as shown in the diagram. The tie rod carries a pull, P of 50kN. If the allowable shear stress is 90MPa, determine the necessary diameter of the bolt required
(5 Marks)

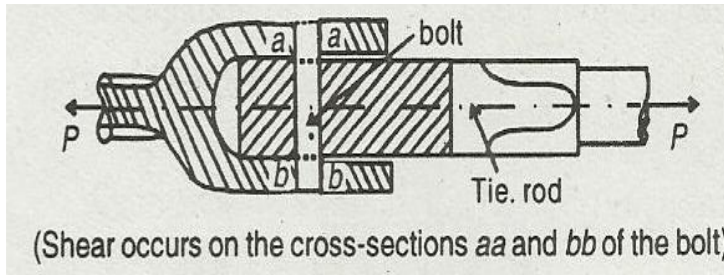

- iii. A steel bar is of 20mm x 40mm section and 400mm long. It is subjected to an axial pull of 200kN. $E=2 \times 10^5$ MPa and Poisson's ratio = 0.3.
- Determine the change in lateral dimensions of the bar and in the volume
 - Determine the change in longitudinal dimension
 - Determine the change in volume **(10Marks)**